

JUMITECH

0-10V to DALI Converter 10mA



Datasheet Interface

Interface for converting 0-10V
control signals to DALI dim levels

Art. Nr. 86468352-xxx

0-10V to DALI Converter Interface

Overview

- Compact interface module for the conversion of 0-10V control signals to DALI dim levels
- The interface module provides a DALI power supply for a small DALI-subnet of up to 4 standard DALI ballasts (10mA), up to 64 DALI ballasts controllable with the help of a DALI-Expander
- Passive and active 0-10V input
- The converted value is sent broadcast on the DALI subnet
- A change in the 0-10V input voltage signal (>1%) is used as trigger event.
- The interface module is supplied by a 12-24V power supply
- Various conversion-characteristics available (dimcharacteristic, OFF-function)
- **A galvanic isolation between the ballasts connected to the DALI-output (10mA) and the 0-10V signal input (and 24V supply input) can be realised with the help of a DALI-Expander**

Specification, Characteristics

Type	0-10V / DALI Converter
article number	86468352-xxx
electrical data:	
supply voltage	12V-24V DC
typ. current consumption	4mA + current for DALI-subnet
input	0-10V, passive or active
output	DALI I _{max} =10mA
function	signal converter, conversion characteristic can be selected by article number
technical data:	
storing and transportation temperature	-20°C to +75°C
operational ambient temperature	-20°C to 60°C
protection class	IP20
connecting wire cross section	0.5-1.5 mm ²
mounting/housing	back box
recommended cable length to 0-10V control device	50cm
dimensions	40 / 28 / 15 mm

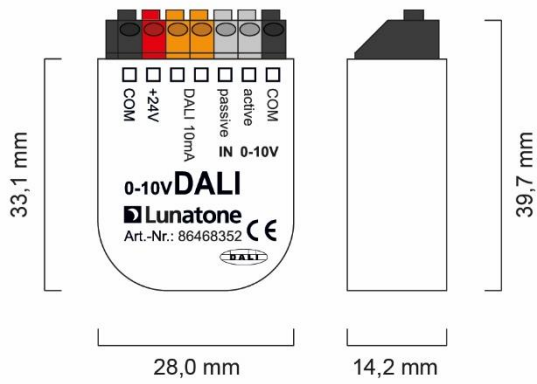

dimensions

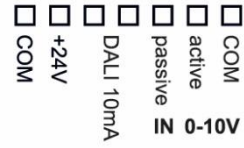

connection plan

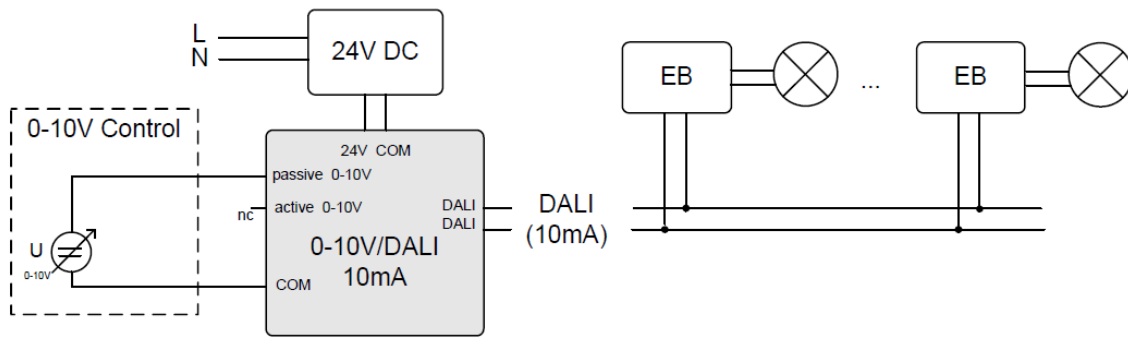

typical application with passive 0-10V input (0-10V control = voltage source)

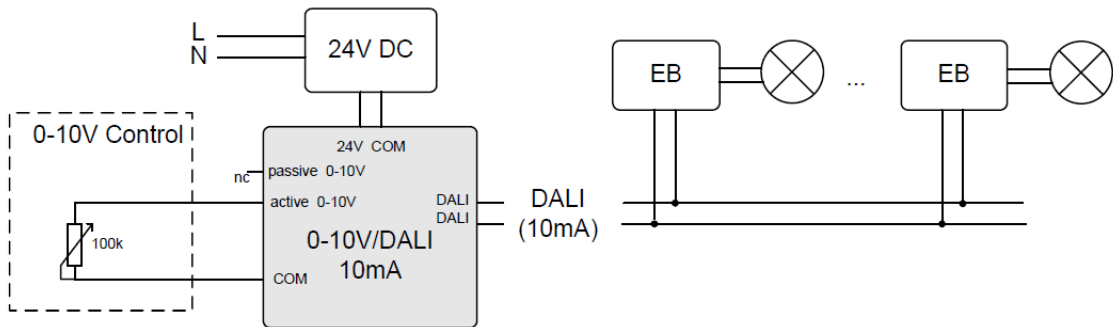

typical application with 100k potentiometer on active 0-10V input (potentiometer = load)

0-10V to DALI conversion

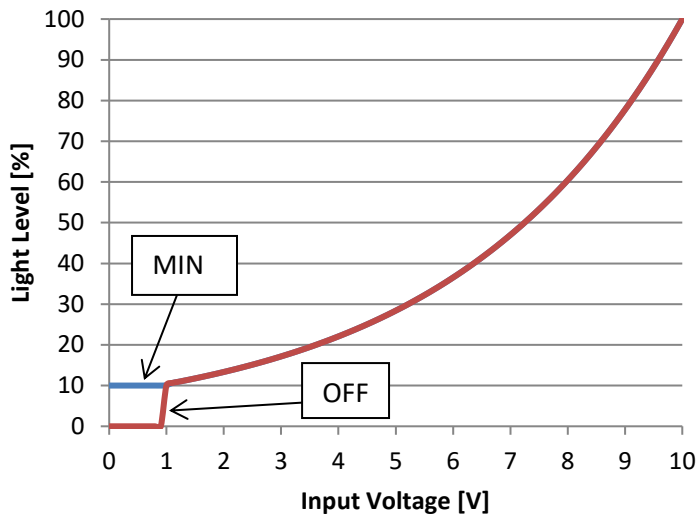

Conversion Curve:

The input voltage range of 1V-10V is converted to the light level range of the connected DALI ballast.

The input voltage is converted to either 1%-100% or 10% -100% light level (depending on the type)

For a better visualisation the characteristics of the 10% types are shown.

MIN/OFF:

Depending on the type the converter behaviour below 1V is different. It is either switched OFF (red characteristic) or the minimum level is recalled (blue characteristic).

The light level is the output power of a standard DALI-ballast (IEC62386-102) which is connected to the converter.

Application Example: Controlling up to 64 ballasts with DALI-Expander

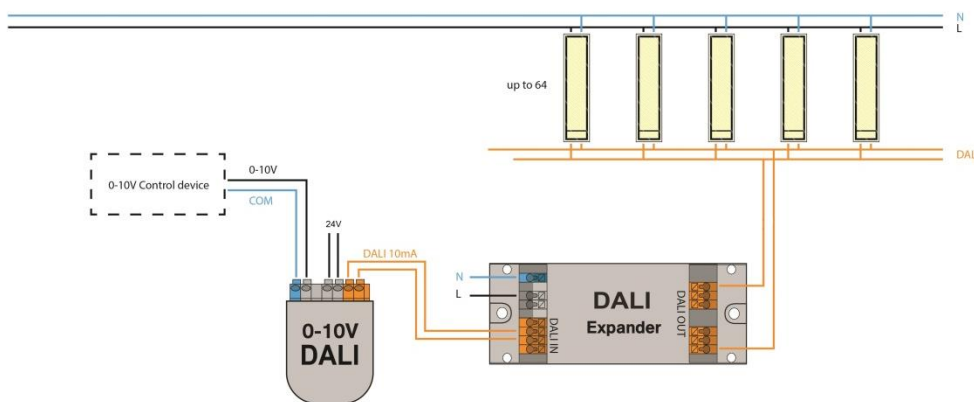

Control of 64 DALI-luminaires with a 0-10V to DALI converter with the help of a DALI Expander (ArtNr: 89453847)

Purchase Information

Art.Nr. 86468352-xxx:

0-10V to DALI converter for the control of a small DALI subnet (broadcast);

Various types differ in dimming range and OFF-function.

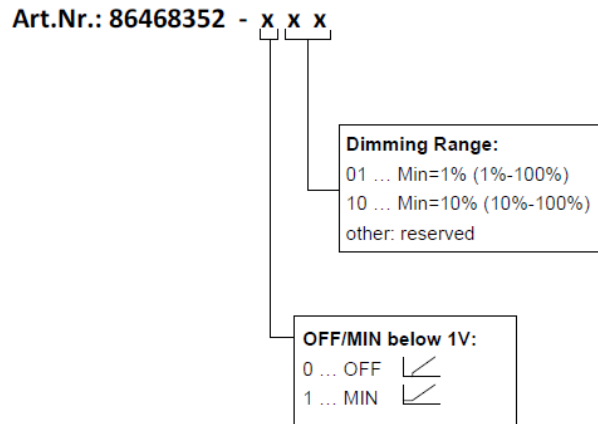

In case of orders without detailed specification the delivered parts correspond to the following item number:

Art.Nr. 86468352-001 (OFF, 1%-100%)

Additional Information

Datasheets and manuals

<https://jumitech/produkter>

Contact

Technical Support: support@jumitech.dk

Requests: salg@jumitech.dk

www.jumitech.dk

JUMITECH



Disclaimer

Subject to change. Information provided without guarantee.
The datasheet refers to the current delivery.

The compatibility with other devices must be tested in advance to the installation.