

# JUMITECH



## DALI RM8/16

### Datasheet DT7 Relay Module

Relay Module for the integration of non-dimmable ballasts in DALI lighting systems (DT7)

Rail mounting

Art.Nr. 86458675-HS (RM8 HS)

Art.Nr. 86458629-HS (RM16 HS)

Art.Nr. 86458629-HS-WE (RM16 HS WE)

Remote ceiling:

Art. Nr. 86458629-DE (RM16 DE)

Art. Nr. 86458629-DE-WE (RM16 DE WE)

Art. Nr. 86458629-CEL (RM16 CEL)



Back box:

Art. Nr. 86458675 (RM8)

Art. Nr. 86458629 (RM16)

# DALI RM 8/16 DT7 Relay Module

## Overview

- Compact relay module for the direct control of 230V AC loads via DALI
- Ballasts without DALI-input can be simply integrated in a DALI lighting control system. The loads can then be switched ON and OFF by DALI commands.
- The DALI RM8/16 module fulfills the requirements for DALI Device Type 7 - switching function (firmware 2.0 and higher)
- Configurable Power-Up and System-Failure behaviour
- Free DALI-Cockpit software package for configuration of DALI-systems and Lunatone DALI components
- The DALI RM 8/16 is supplied directly by the DALI signal line
- Zero cross switching
- RM16-HS und RM16-DE: integrated current limiter, suitable for loads with high inrush current (>100A)
- The DALI RM 8/16 module acts like any conventional DALI ballast. Hence it can be addressed and configured.

## Specification, Characteristics

Rail mounting types:

type	DALI RM16 HS	DALI RM16 HS WE	DALI RM8 HS
article number	86458629-HS	86458629-HS-WE	86458675-HS

electrical data:			
supply	via DALI-line		
typ. current consumption	2.7 mA		
relay output switch on/off voltage	250Vac		
max. nominal load	2000VA	2000VA	1000VA
max. switching current	16A	16A	8A
switching method	zero cross switching integrated current limiter	zero cross switching	zero cross switching
type of relay contact	1 normally open	1 changeover	1 normally open
switching operations at nominal load, resistive	>10 <sup>5</sup>	>3x10 <sup>4</sup>	>10 <sup>5</sup>
maximum switching frequency	1Hz		
Input	DALI		
number of used DALI addresses	1		

type	DALI RM16 HS	DALI RM16 HS WE	DALI RM8 HS
Article number	86458629-HS	86458629-HS-WE	86458675-HS

technical data:			
behaviour at PowerUp	programmable: ON/OFF/no Change		
behaviour at System failure	programmable: ON/OFF/no Change		
storage and transportation temperature	-20°C ... 75°C		
operating ambient temperature	-20°C ... 60°C		
protection class	IP20		
connecting wire cross section	2.5 mm <sup>2</sup>		
dimensions	98mm x 17.5mm x 56mm		

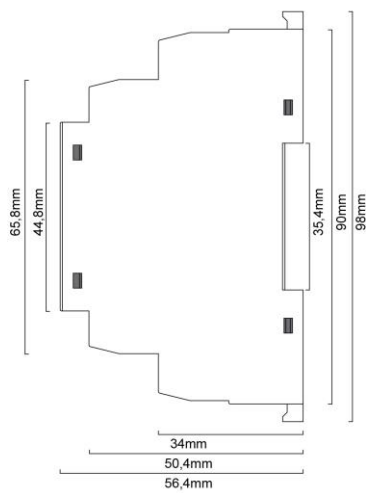

geometry RM8/RM16 HS

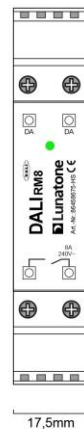

connection plan  
RM8/RM16 HS



connection plan  
RM16 HS WE

Remote ceiling types:

type	DALI RM16 DE	DALI RM16 DE-WE	DALI RM16 CEL
article number	86458629-DE	86458629-DE-WE	86458629-CEL

electrical data:			
supply	via DALI-line		
typ. current consumption	2.7 mA		
relay output switch on/off voltage	250Vac		
max. nominal load	2000VA		
max. switching current	16A		
switching method	zero cross switching integrated current limiter	zero cross switching	zero cross switching
type of relay contact	1 normally open	1 changeover	1 normally open
switching operations at nominal load, resistive	>5x10 <sup>4</sup>	>5x10 <sup>4</sup>	>3x10 <sup>4</sup>
maximum switching frequency	1Hz		
Input	DALI		

number of used DALI addresses	1		
<b>type</b>	<b>DALI RM16 DE</b>	<b>DALI RM16 DE-WE</b>	<b>DALI RM16 CEL</b>
article number	86458629-DE	86458629-DE-WE	86458629-CEL

<b>technical data:</b>			
behaviour at PowerUp	programmable: ON/OFF/no Change		
behaviour at System failure	programmable: ON/OFF/no Change		
storage and transportation temperature	-20°C ... 75°C		
operating ambient temperature	-20°C ... 60°C		
protection class	IP20		
connecting wire cross section	relay output: 2.5 mm <sup>2</sup> DALI: 1.5 mm <sup>2</sup>	2x1.5 mm <sup>2</sup>	-
dimensions	120mm x 30mm x 22mm		85mm x 62mm x 18mm

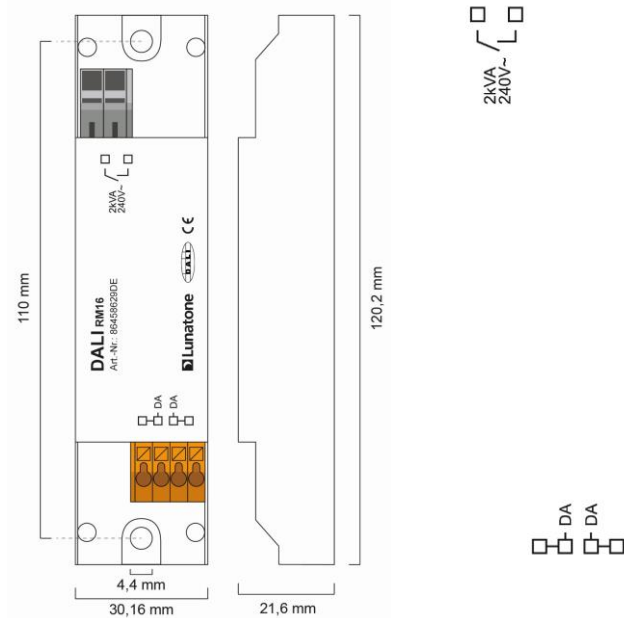

geometry RM16 DE

connection plan RM16 DE

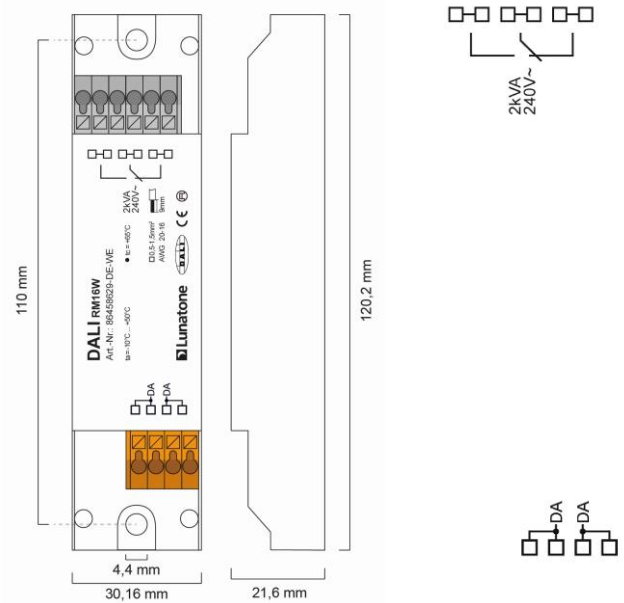

geometry RM16 DE WE

connection plan RM16 DE WE

type with Wieland-connectors:

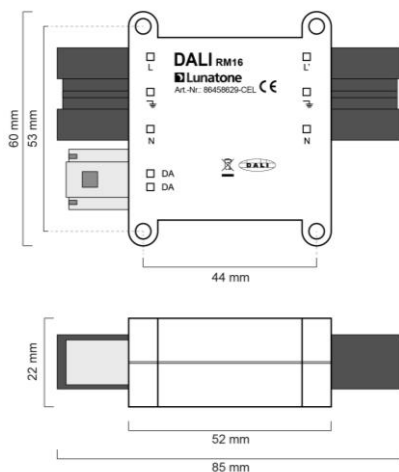

geometry RM16-CEL

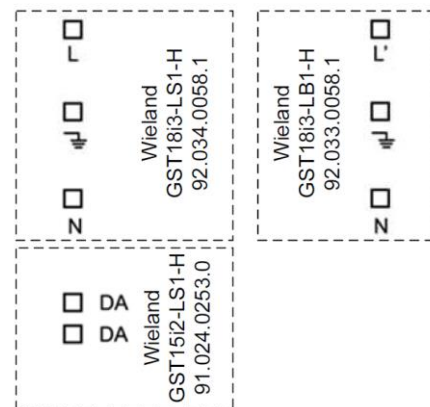

connection plan RM16-CEL

Back box types:

type	DALI RM16	DALI RM8
article number	86458629	86458675

electrical data:		
supply	via DALI-line	
typ. current consumption	2.7 mA	
relay output switch on/off voltage	250Vac	
max. nominal load	1000VA	
max. switching current	8A	
switching method	zero cross switching	
type of relay contact	1 changeover	1 normally open
switching operations at nominal load, resistive	>10 <sup>5</sup>	>10 <sup>5</sup>
maximum switching frequency	1Hz	
input	DALI	
number of used DALI addresses	1	

technical data:	
behaviour at PowerUp	programmable: ON/OFF/no Change
behaviour at System failure	programmable: ON/OFF/no Change
storage and transportation temperature	-20°C ... 75°C
operating ambient temperature	-20°C ... 60°C
protection class	IP20
connecting wire cross section	1.5 mm <sup>2</sup>
dimensions	59mm x 33mm x 15mm

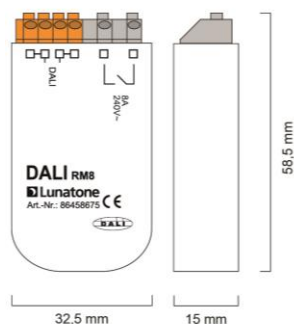

geometry RM8/RM16

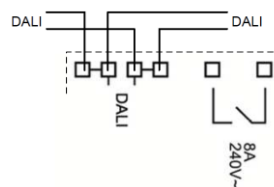

connection plan RM8

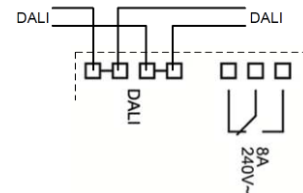

connection plan RM16

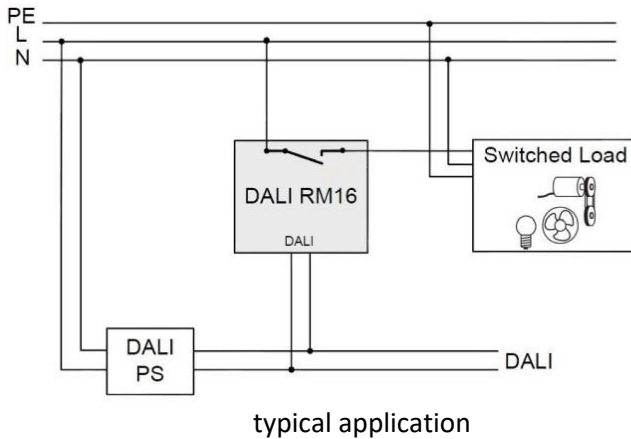

**Hint:** In order to ensure that the load current does not exceed the maximum switching current, the installation must be secured with a suitable automatic circuit breaker.

## Installation

The relay module is supplied directly by the DALI-line. It must NOT be connected to the mains. A typical value of current consumption is 2.7mA. In order to supply components on a DALI line the installation of a DALI power supply (DALI PS) is necessary. The connection to the DALI line is polarity free. The DALI input is protected against overvoltage up to 250VAC. For RM8/16 and RM16-DE types internally the DALI-terminals are connected through as visualized on the housing (see connection plan).

The relay output of the RM8/16 supports loads up to 2000VA and switching currents up to 16A (type dependent, check specification for details). In order to ensure that the load current does not exceed the maximum switching current of the relay a suitable automatic circuit breaker has to be installed. Switching is done at zero cross of ac voltage, type RM16 DE and RM16 HS are also equipped with integrated current limiter and are therefore dedicated for loads with high inrush current >100A.

## DALI Functions and Instruction Set

The DALI RM 8/16 acts as a DALI-controlled relay contact. Hence ballasts can be integrated in a DALI-system and switched on and off by DALI commands.

The DALI RM8/16 acts like a standard DALI ballast for non-dimmable loads. It is based on the DALI specification for control gear (IEC 62386-102) and the device type 7 extension (IEC 62386-208). Therefore the switching characteristic is determined by the comparison of the virtual direct arc power level (VDAP) with 4 thresholds.

The virtual dim level (VDAP) is like the dim level of DALI-ballasts and is therefore limited by MINLEVEL and MAXLEVEL and influenced by fade-time and fade-rate.

For each dim direction 2 thresholds can be defined. They are compared with the virtual dim level and as a result the output is switched on or off:

virtual dim direction	comparison of virtual dim level and thresholds	output
UP	VDAP >= UP SwitchOn Threshold	ON
UP	VDAP >= UP SwitchOff Threshold	OFF
DOWN	VDAP <= DOWN SwitchOn Threshold	ON
DOWN	VDAP <= DOWN SwitchOff Threshold	OFF

If a threshold value is set to "MASK" the threshold is inactive and does not influence the relay output.

Find some examples of switching characteristics below:

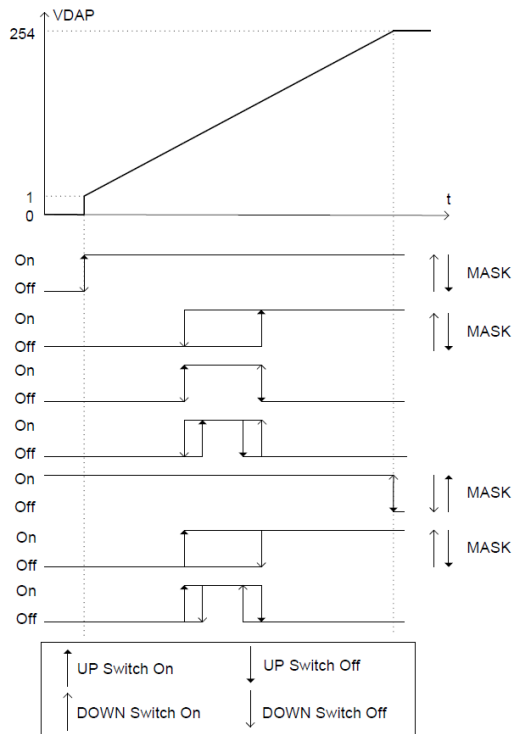

With the help of the fade time switch on and switch off delays can be realized.

The DALI RM8/16 is bus-powered. The reaction on a system failure can be configured (keep relay state, on or off, factory default: on). In case of switching on the DALI-line supply voltage the Power On level is applied.

## Addressing and Configuration

The DALI RM 8/16 can be addressed (random addressing) and configured with the help of the DALI-Cockpit, a software tool, that can be downloaded from the Lunatone website.

## Purchase Information

**Art.Nr. 86458629-HS:** DALI RM16, 2000VA/16A, zero cross switching, integrated current limiter, 1 normal open, rail mounting

**Art.Nr. 86458629-HS-WE:** DALI RM16, 2000VA/16A, zero cross switching, 1 changeover, rail mounting

**Art.Nr. 86458675-HS:** DALI RM8, 1000VA/8A, zero cross switching, 1 normal open, rail mounting

**Art. Nr. 86458629-DE:** DALI RM16, 2000VA/16A, zero cross switching, integrated current limiter, 1 normal open, remote ceiling

**Art. Nr. 86458629-DE-WE:** DALI RM16, 2000VA/16A, zero cross switching, 1 changeover, remote ceiling

**Art. Nr. 86458629-CEL:** DALI RM16, 2000VA/16A, 1 normal open, fast commissioning (plug)

**Art. Nr. 86458629:** DALI RM16, 1000VA/8A, zero cross switching, 1 changeover, back box

**Art. Nr. 86458675:** DALI RM8, 1000VA/8A, zero cross switching, 1 normal open, back box

## Additional Information

Datasheets and manuals

<https://jumitech/produkter>

DALI-Cockpit – free configuration tool from Lunatone for DALI systems

[http://lunatone.at/en/downloads/Lunatone\\_DALI-Cockpit.zip](http://lunatone.at/en/downloads/Lunatone_DALI-Cockpit.zip)

## Contact

Technical Support: [support@jumitech.dk](mailto:support@jumitech.dk)

Requests: [salg@jumitech.dk](mailto:salg@jumitech.dk)

[www.jumitech.dk](http://www.jumitech.dk)

# JUMITECH



## Disclaimer

Subject to change. Information provided without guarantee.  
The datasheet refers to the current delivery.

The function in installations with other devices must be tested  
for compatibility in advance.