

# 4 Channels CV 100W ZigBee Dimmable Driver

09.100ZG.04763



**Important:** Read All Instructions Prior to Installation

## Function introduction

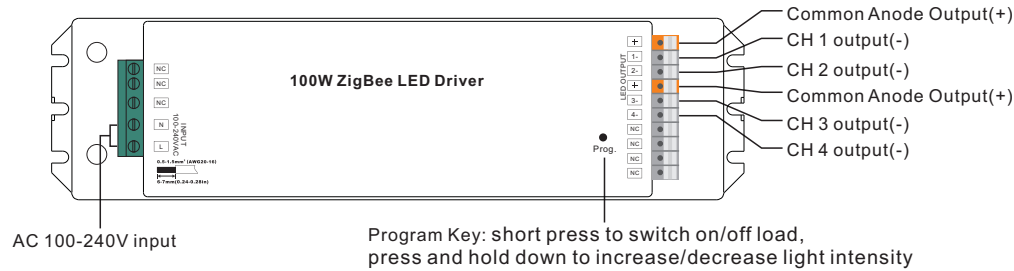

## Product Data

Output	LED Channel	4
	DC Voltage	24V DC
	Max. Current	Max. 4.1A/ch, ch1+ch2+ch3+ch4=4.1A
	Voltage Tolerance	± 1%
	Rated Power	max. 100W
Input	Voltage Range	100-240V AC
	Frequency Range	50/60Hz
	Power Factor (Typ.)	> 0.90 @ 230VAC
	Total Harmonic Distortion	THD ≤ 15% (@ full load / 230VAC)
	Efficiency (Typ.)	90% @ 230VAC full load
	AC Current (Typ.)	1.2A @ 100VAC, 0.5A @ 230VAC
	Inrush Current (Typ.)	Cold Start Max. 50A @ 230VAC
	Leakage Current	< 0.5mA /230VAC
Control	Dimming Interface	ZigBee
	Dimming Range	0.1%-100%
	Dimming Method	Pulse Width Modulation
Protection	Over Current	Yes, recovers automatically after fault condition is removed
	Over Temperature	Yes, recovers automatically after fault condition is removed

Environment	Working Temp.	-20°C ~ +45°C
	Max. Case Temp.	85°C (Ta="45°C")
	Working Humidity	10% ~ 95% RH non-condensing
	Storage Temp. & Humidity	-40°C ~ +80°C, 10% ~ 95% RH
Safety & EMC	Safety Standards	TUV EN61347-1, EN61347-2-13 approved
	Withstand Voltage	I/P-O/P: 3.75KVAC
	Isolation Resistance	I/P-O/P: 100M Ohms / 500VDC / 25°C / 70% RH
	EMC Emission	EN55015, EN61000-3-2, EN61000-3-3
	EMC Immunity	EN61547, EN61000-4-2,3,4,5,6,8,11, surge immunity Line-Line 1KV
Others	MTBF	192500H, MIL-HDBK-217F @ 230VAC at full load and 25°C ambient temperature
	Dimension	244*64*32mm (L*W*H)

- Dimmable LED driver with plastic case, 4 channels 24VDC constant voltage output
- Class 1 power supply, full isolated design
- Built-in two-stage active PFC function, PF > 0.90, Efficiency > 90%
- Compliant with Safety Extra Low Voltage standard
- Over load, over temperature protection
- ZigBee single color LED light device based on ZigBee 3.0 protocol, supports Touchlink commissioning
- Enables to control ON/OFF, light intensity of connected LED light
- Can directly pair to a compatible ZigBee remote via Touchlink
- Supports zigbee green power and can bind max. 20 zigbee green power switches
- Compatible with universal ZigBee coordinator or gateway products
- IP20 rating, suitable for indoor LED lighting applications
- 5 years warranty

## Safety & Warnings

- DO NOT install with power applied to the device.
- DO NOT expose the device to moisture.

## Wiring Diagram

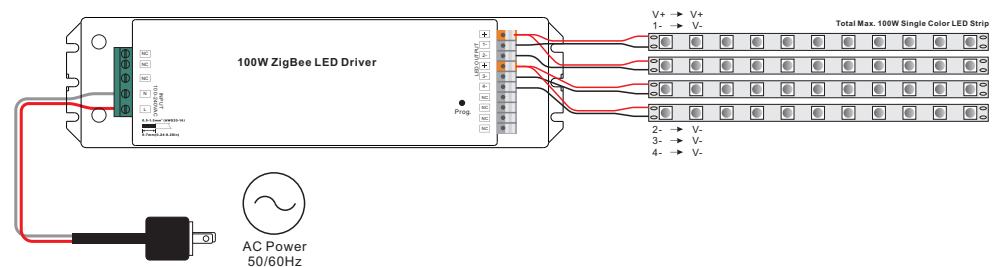

## Operation

1. Do wiring according to connection diagram correctly.

2. This ZigBee device is a wireless receiver that communicates with a variety of ZigBee compatible systems. This receiver receives and is controlled by wireless radio signals from the compatible ZigBee system.

### 3. Zigbee Network Pairing through Coordinator or Hub (Added to a Zigbee Network)

**Step 1:** Remove the device from previous zigbee network if it has already been added to, otherwise pairing will fail. Please refer to the part "Factory Reset Manually".

**Step 2:** From your ZigBee Controller or hub interface, choose to add lighting device and enter Pairing mode as instructed by the controller.

**Step 3:** power on the device, it will be set into network pairing mode (connected light flashes twice slowly), the network pairing mode will last until the device is added to a zigbee network.

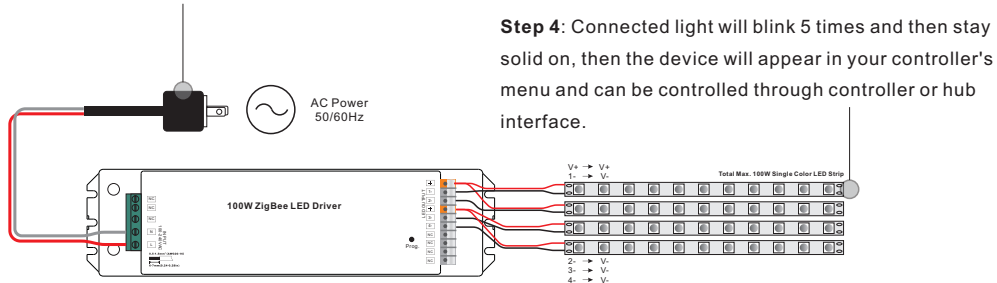

### 4. TouchLink to a Zigbee Remote

**Step 1: Method 1:** Short press "Prog" button 4 times (or re-power on the device 4 times) to start Touchlink commissioning immediately, 180S timeout, repeat the operation.

**Method 2:** Add the device to a Zigbee network, then it will be set into Touchlink commissioning immediately, 180S timeout. Once timeout, re-power on the device to set it into touchlink commissioning again.

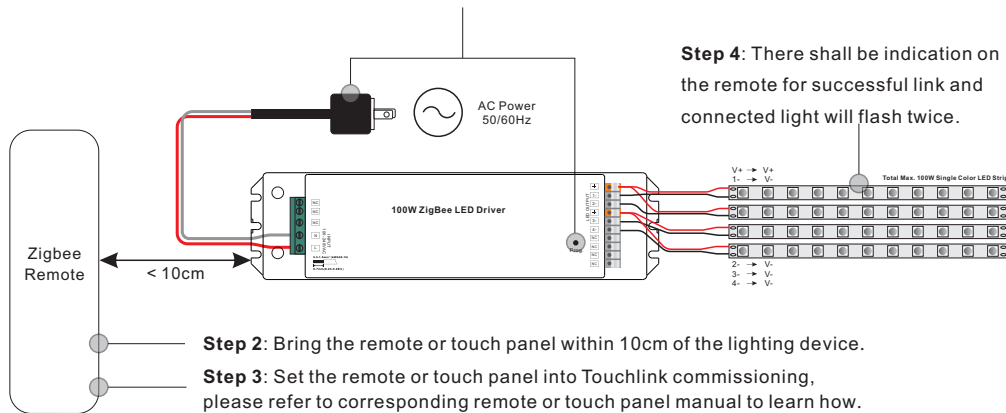

- Note:**
- 1) Directly TouchLink (both not added to a ZigBee network), each device can link with 1 remote.
  - 2) TouchLink after both added to a ZigBee network, each device can link with max. 30 remotes.
  - 3) To control by both gateway and remote, add remote and device to network first then TouchLink.
  - 4) After TouchLink, the device can be controlled by the linked remotes.

### 5. Removed from a Zigbee Network through Coordinator or Hub Interface

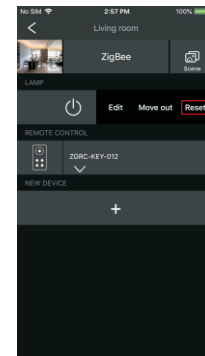

From your ZigBee controller or hub interface, choose to delete or reset the lighting device as instructed. The connected light blinks 3 times to indicate successful reset.

### 6. Factory Reset Manually

**Step 1:** Short press "Prog." key for 5 times continuously or reset power of the device for 5 times continuously if the "Prog." key is not accessible.

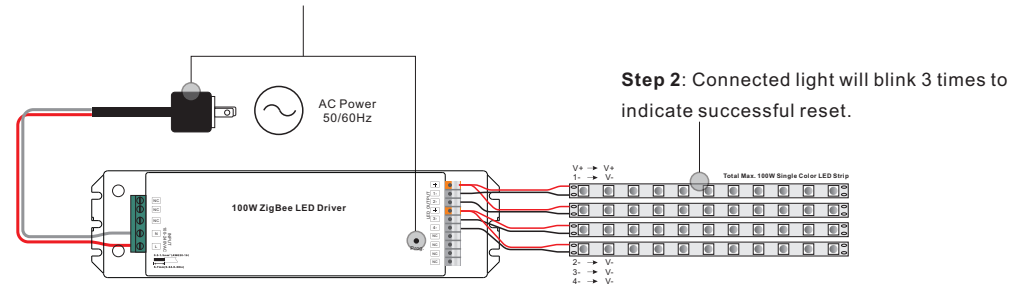

- Note:**
- 1) If the device is already at factory default setting, there is no indication when factory reset again.
  - 2) All configuration parameters will be reset after the device is reset or removed from the network.

### 7. Factory Reset through a Zigbee Remote (Touch Reset)

**Note:** Make sure the device already added to a network, the remote added to the same one or not added to any network.

**Step 1:** Reset power of the device to start TouchLink Commissioning, 180 seconds timeout, repeat this step.

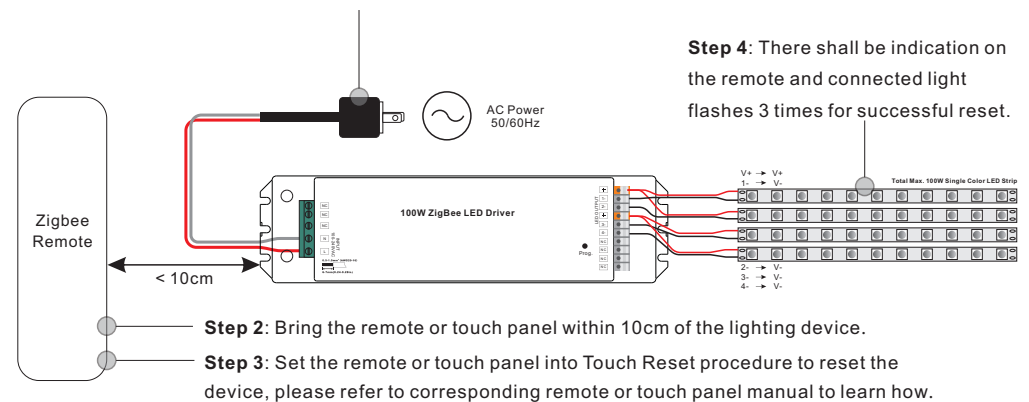

## 8. Find and Bind Mode

**Step 1:** Short press “Prog.” button 3 times (Or reset power of the device (initiator node) 3 times) to start Find and Bind mode (connected light flashes slowly) to find and bind target node, 180 seconds timeout, repeat this step.

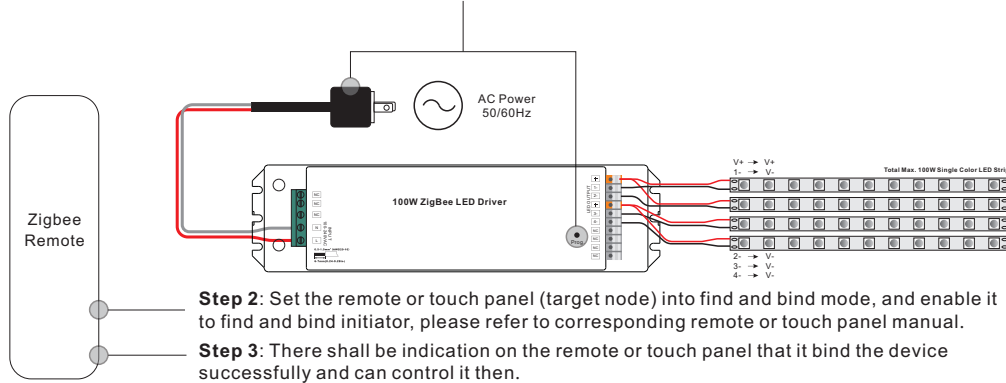

## 9. Learning to a Zigbee Green Power Switch

**Step 1:** Short press “Prog.” button 4 times (Or reset power of the device 4 times) to start Learning mode (connected light flashes twice), 180 seconds timeout, repeat this step.

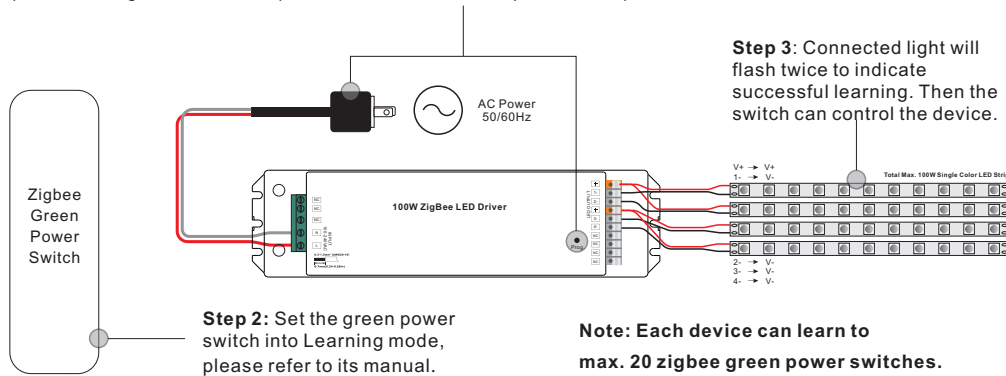

## 10. Delete Learning to a Zigbee Green Power Switch

**Step 1:** Short press “Prog.” button 3 times (Or reset power of the device 3 times) to start delete Learning mode (connected light flashes slowly), 180 seconds timeout, repeat this step.

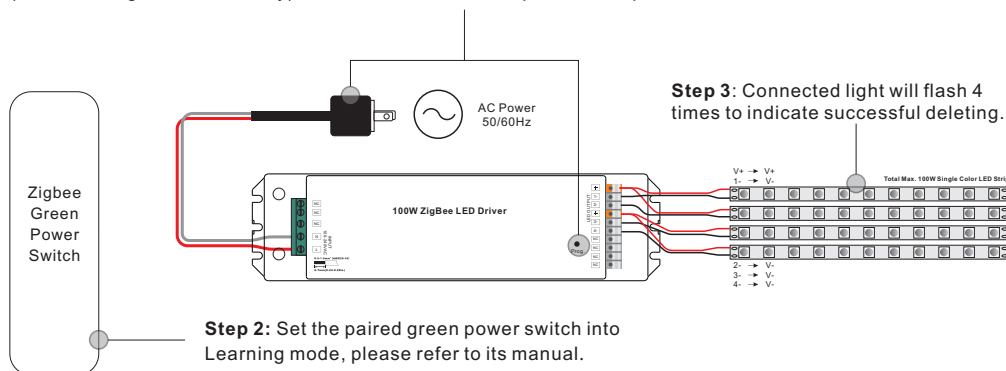

## 11. Setup a Zigbee Network & Add Other Devices to the Network (No Coordinator Required)

**Step 1:** Short press “Prog.” button 4 times (Or reset power of the device 4 times) to enable the device to setup a zigbee network (connected light flashes twice) to discover and add other devices, 180 seconds timeout, repeat this step.

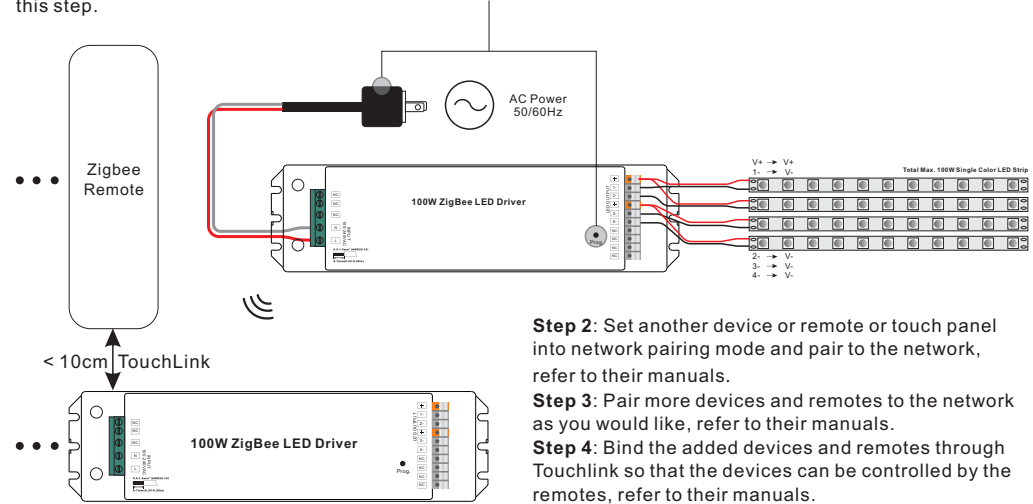

**Note:** 1) Each added device can link and be controlled by max. 30 added remotes.  
2) Each added remote can link and control max. 30 added devices.

## 12. ZigBee Clusters the device supports are as follows:

### Input Clusters

- 0x0000: Basic
- 0x0003: Identify
- 0x0004: Groups
- 0x0005: Scenes
- 0x0006: On/off
- 0x0008: Level Control
- 0x0b05: Diagnostics

### Output Clusters

- 0x0019: OTA

## 13. OTA

The device supports firmware updating through OTA, and will acquire new firmware from zigbee controller or hub every 10 minutes automatically.

## Product Dimension

